

MV-CH250-90XM

25 MP 1.1" CMOS CoaXPress Area Scan Camera



GEN*i*CAM

Introduction

MV-CH250-90XM camera adopts Gpixel GMAX0505 sensor to provide high quality image. It uses CXP-6 interface to transmit non-compressed images in real time, and its max. frame rate can reach 41.5 fps in full resolution.

Key Feature

- Resolution of 5120 × 5120, pixel size of 2.5 μm × 2.5 μm.
- Adopts global shutter CMOS sensor to provide high dynamic range, SNR, and high-quality image.
- Adopts CXP-6 interface to transmit data.
- Supports Off, Once, and Continuous exposure modes.
- Compatible with CoaXPress Protocol, GenICam Standard, and third-party software based on the protocol and standard.

Dimension

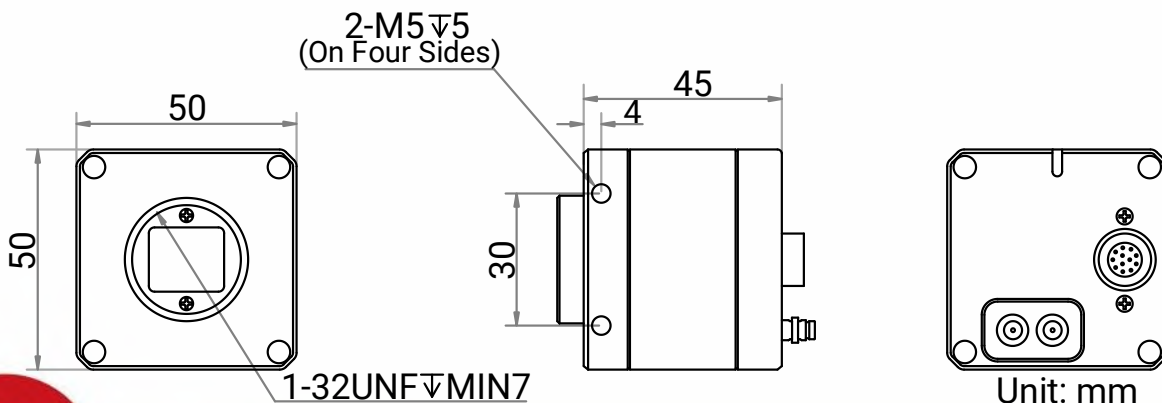

Available Model

MV-CH250-90XM-C-NN

Applicable Industry

Electron semiconductor, PCB AOI, 3D application, motion capture, etc.

Sensor Quantum Efficiency

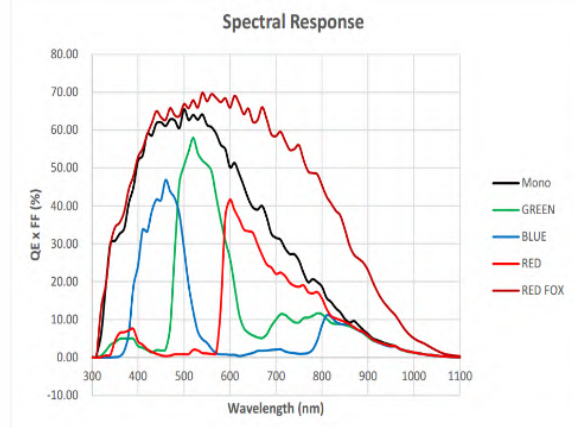

Specification

Model	MV-CH250-90XM
Performance	
Sensor type	CMOS, global shutter
Sensor model	Gpixel GMAX0505
Pixel size	2.5 μm \times 2.5 μm
Sensor size	1.1"
Resolution	5120 \times 5120
Max. frame rate	41.5 fps @5120 \times 5120 Mono 8
Dynamic range	65 dB
SNR	41 dB
Gain	Supports 2.0 \times , 2.5 \times , 3.0 \times , 3.5 \times , 4.0 \times , 4.5 \times , 5.0 \times
Exposure time	13 μs to 10 sec
Exposure mode	Off/Once/Continuous exposure mode
Mono/color	Mono
Pixel format	Mono 8/10/12
Binning	Supports 1 \times 1, 1 \times 2, 1 \times 4, 2 \times 1, 2 \times 2, 2 \times 4, 4 \times 1, 4 \times 2, 4 \times 4
Decimation	Supports 1 \times 1, 1 \times 2, 1 \times 4, 2 \times 1, 2 \times 2, 2 \times 4, 4 \times 1, 4 \times 2, 4 \times 4
Reverse image	Supports horizontal and vertical reverse image output
Electrical features	
Data interface	CoaXPress with DIN interface
Digital I/O	12-pin P10 connector provides power and I/O, including opto-isolated input \times 1 (Line 0), opto-isolated output \times 1 (Line 1), bi-directional non-isolated I/O \times 1 (Line 2), and RS-232 \times 1.
Power supply	9 VDC to 24 VDC, CXP-1 supports PoCXP
Power consumption	Typ. 7.0 W@24 VDC
Mechanical	
Lens mount	C-mount, flange back focal length 17.52 mm (0.7")
Dimension	50 mm \times 50 mm \times 45 mm (2.0" \times 2.0" \times 1.8")
Weight	Approx. 207 g (0.5 lb.)
Ingress protection	IP40 (under proper lens installation and wiring)
Temperature	Working temperature: 0 $^{\circ}\text{C}$ to 50 $^{\circ}\text{C}$ (32 $^{\circ}\text{F}$ to 122 $^{\circ}\text{F}$) Storage temperature: -30 $^{\circ}\text{C}$ to 70 $^{\circ}\text{C}$ (-22 $^{\circ}\text{F}$ to 158 $^{\circ}\text{F}$)
Humidity	20% to 95% RH, non-condensing
General	
Client software	MVS or third-party software meeting with CoaXPress Protocol
Operating system	32/64-bit Windows 7/10
Compatibility	CoaXPress, GenICam
Certifications	CE, RoHS, KC

HIKROBOT

Hangzhou Hikrobot Co., Ltd.
en.hikrobotics.com

© Hangzhou Hikrobot Co., Ltd. All Rights Reserved.
Hangzhou Hikrobot does not tolerate any infringement. Any organization or individual may not imitate or reproduce in whole or in part of the content. The data herein is based on Hikrobot's internal evaluation. Actual data may vary depending on specific configuration and operating condition. The information herein is subject to change without notice. All the content has been checked conscientiously. Nevertheless, Hikrobot shall not be liable to damages resulting from errors, inconsistencies or omissions.