

MV-CH6040-10XM

604 MP CMOS CoaXPress Area Scan Camera



GEN*i*CAM

CoaXPress®

Introduction

MV-CH6040-10XM camera adopts Sony® IMX411 sensor to provide high-quality images. It uses CXP-6 interface to transmit non-compressed images in real time, and its max. frame rate can reach 1.45 fps in full resolution.

Key Feature

- Resolution of 28416 × 21280, pixel size of 3.76 μm × 3.76 μm.
- Supports 151 MP or 604 MP resolution mode.
- Adopts ISP algorithm to improve image quality.
- Supports FFC correction and 16-bit ADC output.
- Adopts CXP-6 interface to transmit data.
- Compatible with CoaXPress Protocol and GenICam Standard, and third-party software based on the protocol and standard.

Dimension

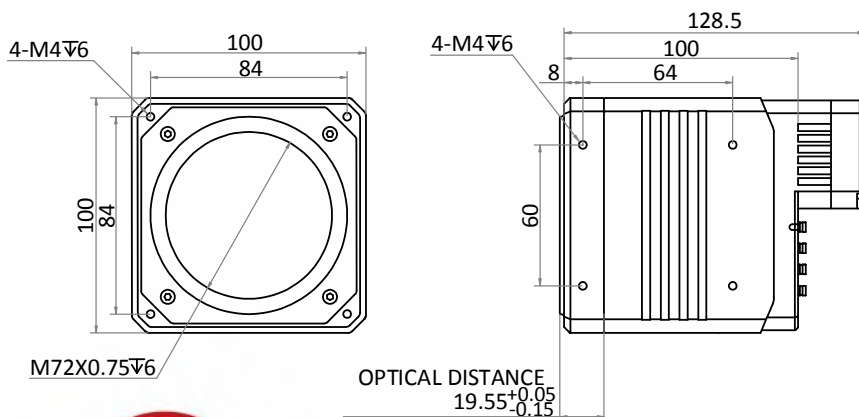

Available Model

MV-CH6040-10XM-M72-NF

Applicable Industry

FPD detection, PCB AOI, file scanning, etc.

Sensor Quantum Efficiency

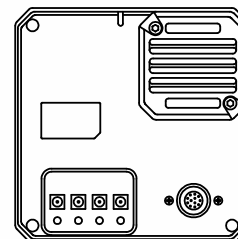
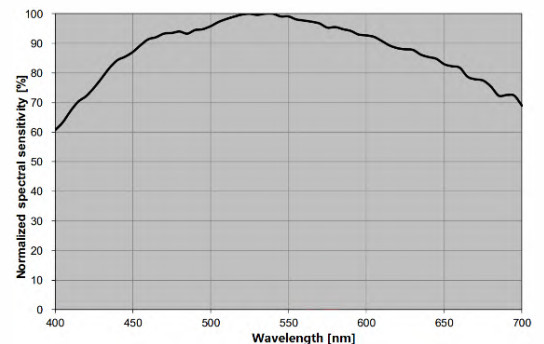

Unit: mm



Specification

Model	MV-CH6040-10XM
Camera	
Sensor type	CMOS, rolling shutter
Sensor model	Sony® IMX411
Pixel size	3.76 μm × 3.76 μm
Sensor size	66.7 mm
Resolution	28416 × 21280
Max. frame rate	1.45 fps @28416 × 21280
Dynamic range	78.7 dB
SNR	46.4 dB
Gain	0 dB to 40 dB
Exposure time	15 μs to 1 sec (604 MP)
Exposure mode	Off/Once/Continuous exposure mode, supports Rolling and Global Reset
Mono/color	Mono
Pixel format	Mono 8/10/12/16
Binning	Supports 1 × 1, 1 × 2, 1 × 4, 2 × 1, 2 × 2, 2 × 4, 4 × 1, 4 × 2, 4 × 4
Decimation	Not support
Reverse image	Supports horizontal reverse image output
Electrical features	
Data interface	CoaXPress with DIN interface
Digital I/O	12-pin P10 connector provides power and I/O, including opto-isolated input × 1 (Line 0), opto-isolated output × 1 (Line 1), bi-directional non-isolated I/O × 1 (Line 2), and RS-232 × 1.
Power supply	24 VDC
Power consumption	Typ. 15 W@24 VDC
Mechanical	
Lens mount	M72-mount, optical back focal length 19.55 mm (0.8")
Dimension	100 mm × 100 mm × 128.5 mm (3.9" × 3.9" × 5.1")
Weight	Approx. 1.4 kg (3.1 lb.)
Ingress protection	IP40 (under proper lens installation and wiring)
Temperature	Performance temperature: 20 °C to 35 °C (68 °F to 95 °F) Working temperature: 0 °C to 50 °C (32 °F to 122 °F) Storage temperature: -30 °C to 70 °C (-22 °F to 158 °F)
Humidity	20% to 95% RH, non-condensing
General	
Client software	MVS or frame grabber software meeting with CoaXPress Protocol
Operating system	64-bit Windows 7/10 with 16 GB memory or above
Compatibility	CoaXPress, GenICam
Certification	CE, FCC, RoHS, KC

HIKROBOT

Hangzhou Hikrobot Technology Co., Ltd.
No.399 Danfeng Road, Binjiang District, Hangzhou 310051, China.
en.hikrobotics.com

MaxxVision®
Sigmaringer Str. 121
70567 Stuttgart
Tel.: 0711 997 996 3
www.maxxvision.com

Copyright Hikrobot

Hangzhou Hikrobot Technology Co., Ltd. All Rights Reserved. Hangzhou Hikrobot Technology does not tolerate any infringement. Any organization or individual may not imitate or reproduce in whole or in part of the content. The data herein is based on Hikrobot's internal evaluation. Actual data may vary depending on specific configuration and operating condition. The information herein is subject to change without notice. All the content has been checked conscientiously. Nevertheless, Hikrobot shall not be liable to damages resulting from errors, inconsistencies or omissions.