

MV-CI003-GL-N15

0.3 MP GigE Industrial Long Wave Infrared Camera



GEN<i>CAM

GigE
VISION

Introduction

MV-CI003-GL-N15 camera adopts a high-sensitivity vanadium oxide uncooled detector with a response band of 8 μm to 14 μm , and supports multiple palette modes. It uses GigE interface to transmit images in real time, and its max. frame rate can reach 50 fps in full resolution.

Available Model

MV-CI003-GL-N15

Applicable Industry

Photovoltaics, lithium battery, consumer electronics, etc.

Dimension

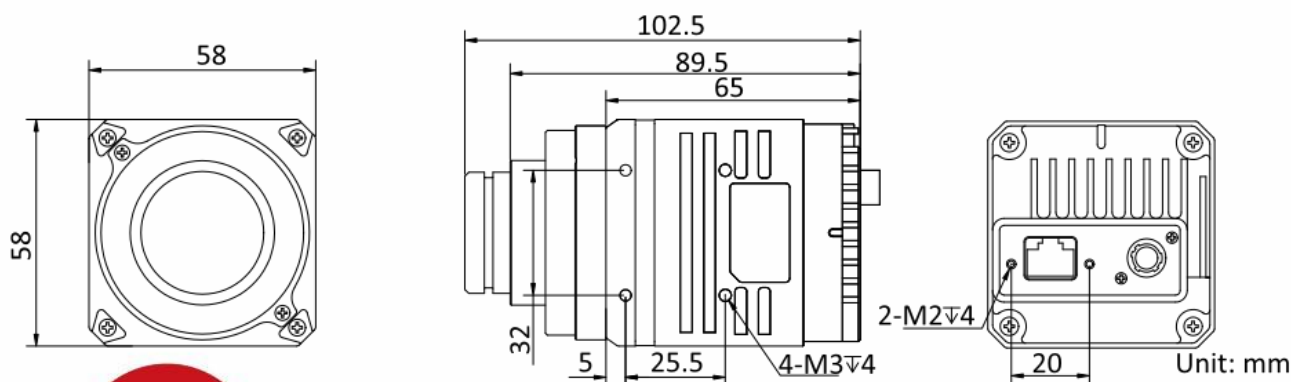

Key Feature

- Adopts high-sensitivity vanadium oxide uncooled detector with 0.3 MP.
- Supports multiple palette modes, grayscale detection, image adjustment, etc.
- Compact design with mounting holes on panels for flexible mounting from 4 sides.
- Adopts GigE interface and max. transmission distance of 100 meters without relay.
- Compatible with GigE Vision V2.0 Protocol, GenlCam Standard, and third-party software based on the protocol and standard.



Specification

Model	MV-CI003-GL-N15
Performance	
Sensor type	Vanadium oxide uncooled detector
Pixel size	17 μ m
Resolution	640 \times 512
Max. frame rate	50 fps @640 \times 512
NETD	< 35 mk (F1.0, 25 $^{\circ}$ C)
Response time	< 10 ms
Pixel format	Mono 8/12/14, YUV422_YUYV_Packed
Color palettes	White Hot, Black Hot, Fusion 1, Rainbow, Fusion 2, Ironbow 1, Ironbow 2, Sepia, Color 1, Color 2, Ice Fire, Rain, Green Hot, Red Hot, Dark Blue
Image process	Supports brightness, contrast, image detail strength, digital noise reduction (spatial and temporal)
Focal length	15 mm
Field of view	42.4 $^{\circ}$ \times 33.6 $^{\circ}$
Min. operation distance	0.1 m
Electrical feature	
Data interface	Gigabit Ethernet, compatible with Fast Ethernet
Digital I/O	6-pin P7 connector provides power and I/O, including opto-isolated input \times 1 (Line 0), opto-isolated output \times 1 (Line 1), bi-directional non-isolated I/O \times 1 (Line 2).
Power supply	9 VDC to 24 VDC, supports PoE
Power consumption	Typ. 2.5 W@12 VDC
Mechanical	
Lens mount	M34*0.75
Dimension	58 mm \times 58 mm \times 102.5 mm (2.3" \times 2.3" \times 4.0")
Weight	Approx. 275 g (0.6 lb.)
Ingress protection	IP40 (under proper lens installation and wiring)
Temperature	Working temperature: -30 $^{\circ}$ C to 60 $^{\circ}$ C (-22 $^{\circ}$ F to 140 $^{\circ}$ F) Storage temperature: -30 $^{\circ}$ C to 70 $^{\circ}$ C (-22 $^{\circ}$ F to 158 $^{\circ}$ F)
Humidity	20% to 90% RH, non-condensing
General	
Client software	MVS or third-party software meeting with GigE Vision Protocol
Operating system	32/64-bit Windows XP/7/10, 32/64-bit Linux and 64-bit MacOS
Compatibility	GigE Vision V2.0, GenICam
Certification	CE, RoHS, KC

HIKROBOT

Hangzhou Hikrobot Co., Ltd.
en.hikrobotics.com

© Hangzhou Hikrobot Co., Ltd. All Rights Reserved.

Hangzhou Hikrobot does not tolerate any infringement. Any organization or individual may not imitate or reproduce in whole or in part of the content. The data herein is based on Hikrobot's internal evaluation. Actual data may vary depending on specific configuration and operating condition. The information herein is subject to change without notice. All the content has been checked conscientiously. Nevertheless, Hikrobot shall not be liable to damages resulting from errors, inconsistencies or omissions.